

### Application:

The pressure independent control valve “Cocon QTR” is designed to be installed in central heating and cooling systems with closed water circuits (like fan convectors (fan coil units), chilled ceiling modules, induction air systems, cooling and heating zones) for an automatic flow control (hydraulic balancing) and the control of another variable (e.g. room temperature) by modifying the flow rate with the help of actuators (see next page). When used in combination with actuators, the setting sleeve (spanner size 17) has to be unscrewed.

The installation advice for the actuators are detailed in the respective installation and operating instructions.

### Technical data:

Max. operating temperature: +120 °C

Min. operating temperature: -10 °C

Max. operating pressure: 16 bar (1600 kPa) (1146172/74)  
25 bar (2500 kPa) (1146112/16  
1143116)

Max. differential pressure: 4 bar (400 kPa)  
6 bar (600 kPa) for item no.  
1143116

Fluid: Water or mixtures of water and ethylene/propylene glycol (max. 50 %), pH value 6.5-10

Max. closing pressure in flow direction: 16 bar (1600 kPa) (1146172/74)  
25 bar (2500 kPa) (1146112/16  
1143116)

### Control range:

Item no.	DN	Control range [m³/h] (min.-max.)	k <sub>vs</sub> value	Differential pressure p <sub>1</sub> -p <sub>3</sub> (min.-max.)
1146112	40	1.5 - 7.5	11.5	0.2 bar-4 bar (20 kPa-400 kPa)
1146172	40	1.5 - 7.5	11.5	
1146116	50	2.5 - 10.0	15.0	
1146174	50	2.5 - 10.0	15.0	
1143116	50	3.5 - 14.0	18,5	0.2 bar-6 bar (20 kPa-400 kPa)

\* Recommended lowest setting; starting from the set value, the flow rate can be reduced up to complete isolation with a suitable actuator.

### Materials:

Bronze body, seals made of EPDM or PTFE, inner parts made of DZR brass, maintenance-free stem seal due to double O-ring.

### Models:

“classic” measuring technique  
-both ports female thread according to EN 10226 or  
-both ports male thread

### Function:

The Oventrop pressure independent control valve “Cocon QTR” is a valve combination consisting of an automatic flow controller (with manually adjustable nominal value) and a regulating valve which may be equipped with an actuator.

### Advantages:

- presetting of the nominal values even with mounted actuator
- optical display of the set nominal value even with mounted actuator
- excellent optical display of the presetting in any installation position
- nominal values can be read off in m³/h without conversion
- presetting can be locked and lead sealed
- constant high valve authority
- installation can be optimised by measuring the regulating pressure
- linear characteristic line if actuator driven

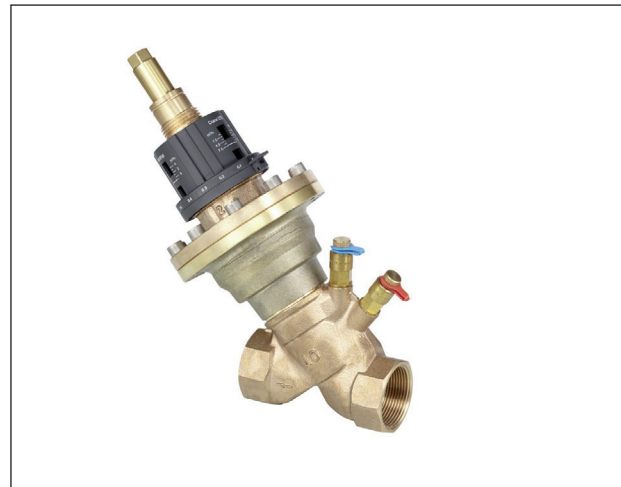

Pressure independent control valve “Cocon QTR”

### Legend:

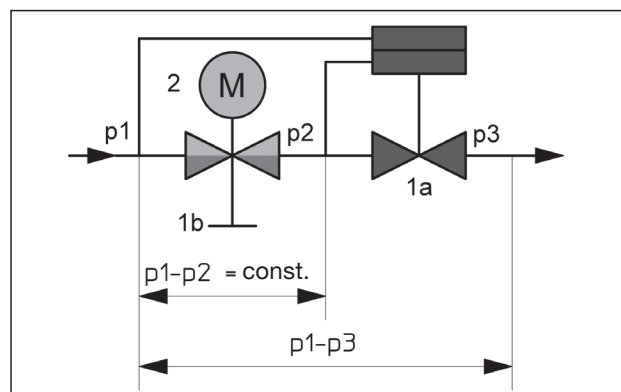
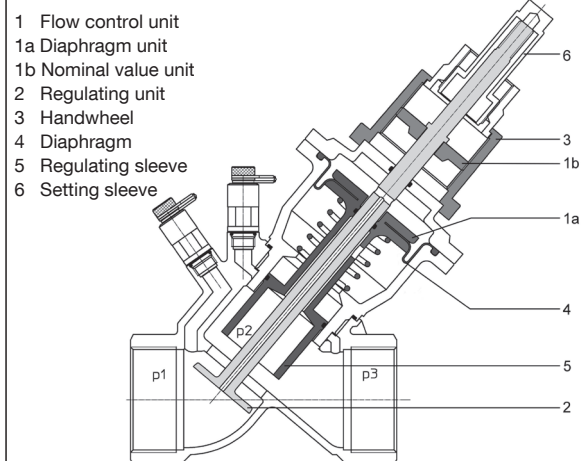

The illustrated section of the pressure independent control valve “Cocon QTR” shows three pressure ranges.

“p<sub>1</sub>” is the inlet pressure and “p<sub>3</sub>” the outlet pressure of the valve. “p<sub>2</sub>” is the pressure actuating the diaphragm unit (pos. 1a) which maintains the differential pressure “p<sub>1</sub>” - “p<sub>2</sub>” at a constant level.

### Accessories:

Lead locking set, item no.1089091

The integrated diaphragm unit (pos. 1a) maintains the differential pressure “p1”- “p2” at a constant level not only across the regulating unit (pos. 2) activated by the actuator but also across the nominal value unit (pos. 1b) which can be set to a maximum flow value. Even where high differential pressure variations “p1” - “p3” occur, for instance if sections of the system are activated or inactivated, the differential pressure “p1” - “p2” is kept at a constant level.

This way the valve authority of the “Cocon QTR” valves amounts to 100 % (a = 1). Even during low demand periods with steady control (for instance in combination with 0-10 V actuators), the valve authority within the effective valve lift amounts to 100 % (a = 1).

The pressure independent control valve “Cocon QTZ” has a linear characteristic line within the effective valve lift. This is advantageous when using actuators which also have a linear stroke behaviour across the control voltage.

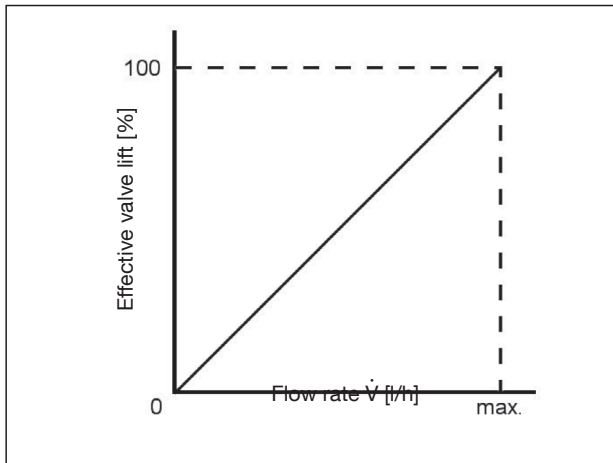

Characteristic line of the “Cocon QTR” valve

**Actuator models:**

**Item no.:**

- |   |         |
|---|---------|
| Actuator with squeeze connection (DN 40/50)<br>24 V, steady 0 – 10 V  | 1158010 |
| Actuator with squeeze connection (DN 40 up to 100)<br>24 V, steady 0(2) – 10 V  | 1158020 |
| Actuator with squeeze connection (DN 40 up to 100)<br>24 V, steady 0 – 10 V or 4 – 20 mA<br>additionally with spring return (opening with current “off”)  | 1158021 |
| Actuator with squeeze connection (DN 40 up to 100)<br>24 V, steady 0 – 10 V or 4 – 20 mA,<br>additionally with spring return (closing with current “off”) | 1158022 |

**Setting of the flow rate:**

The required flow rate can be set with the help of the handwheel and the setting sleeve.

The setting can only be modified after release of the setting sleeve.

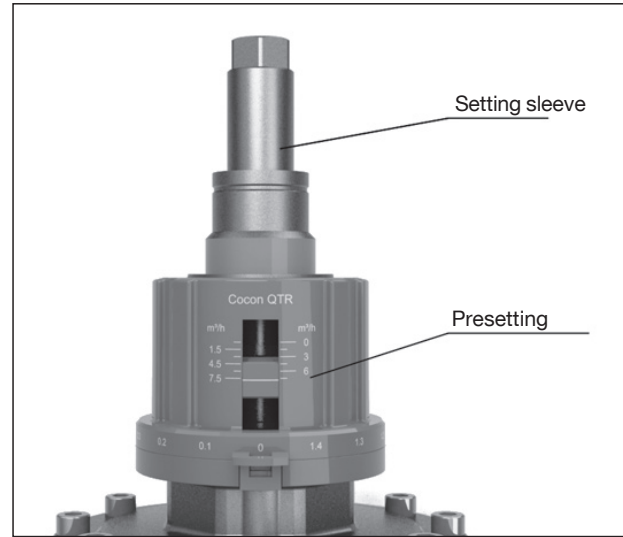

Setting sleeve

**Protection and locking:**

The presetting can be secured and lead sealed with a locking clip.

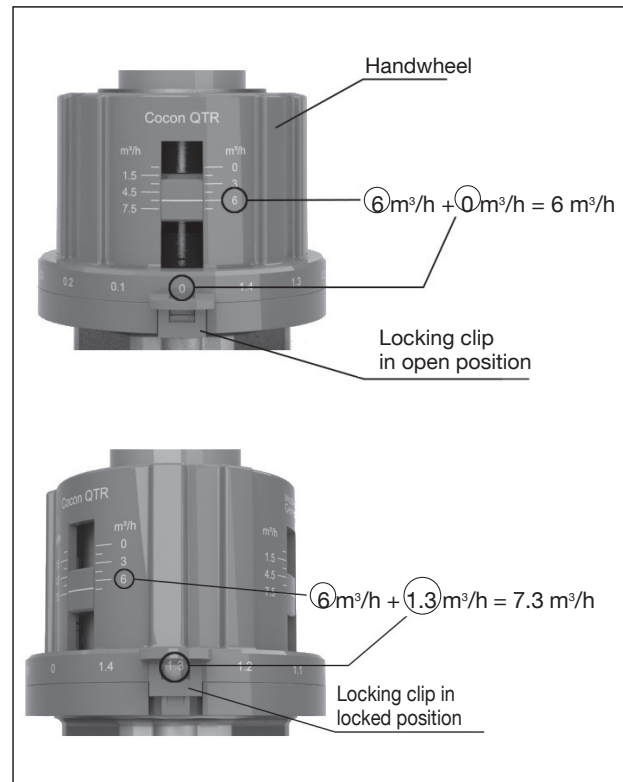

Example settings

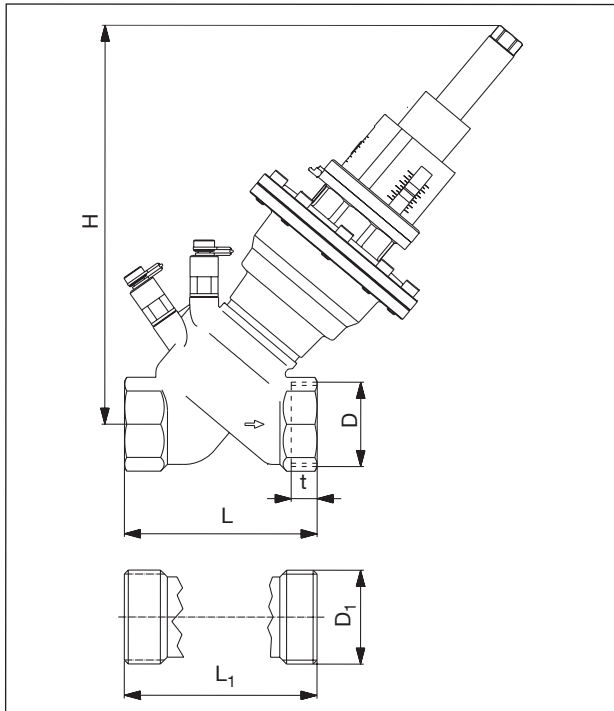

DN	D	D <sub>1</sub>	L	L <sub>1</sub>	t	H
40	Rp 1½	–	120	–	19.1	245
	–	G 1¼	–	120	–	245
50	Rp 2	–	150	–	25.7	255
	–	G 2⅜	–	150	–	255

Dimensions

Installation:

- The direction of flow must conform to the arrow on the valve body.
- The valve may be installed in any position (electric actuators must not be installed in a vertical downward position).
- Do not use any greasing agents or oil for the installation, as these can destroy the seals. Any dirt particles or grease or oil residues must be flushed out of the pipework before the valve is installed.
- Any tension which could be transferred through the pipework must be avoided.
- When choosing the operating fluid, the latest technical status has to be considered (e.g. VDI 2035).
- The installation of an isolating valve in front of and behind the valve or section of the system is recommended for maintenance work.
- A strainer must be installed in the supply pipe to avoid contaminated operating fluids (see VDI 2035).
- The correction factors of the manufacturers of the antifreezes liquids have to be considered when setting the flow rate.
- After installation, check all installation points for leaks.

Min. differential pressure p<sub>1</sub>-p<sub>3</sub> for the valve design:

The minimum required differential pressure p<sub>1</sub>-p<sub>3</sub> across the valve can be obtained from the chart on the top right hand side.

Explanation of chart:

As for valves with integrated flow control, the required minimum differential pressure changes depending on the nominal value setting. The mathematical interrelationship is considered in the chart.

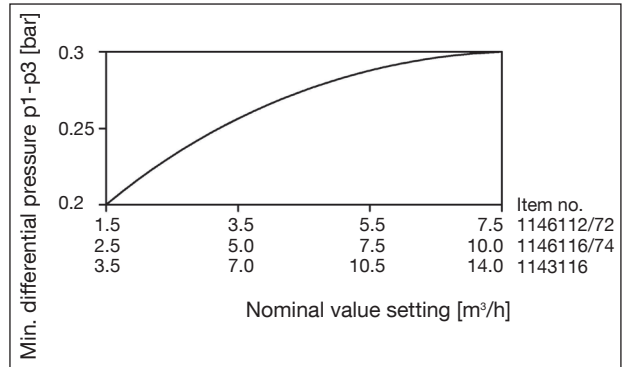

Max. differential pressure 4 bar (400 kPa)

Pressure test points:

The measuring system “OV-DMC 2/OV-DMC 3” can be connected to the pressure test points. This will confirm if the valve is working within the control range. The pump setting can be optimised by measuring the differential pressure.

For this purpose, the pump head is reduced until the hydraulically underprivileged valves are just working within the control range. The minimum differential pressures have to be considered. As soon as the measured differential pressure is identical with or higher than the minimum differential pressure p<sub>1</sub>-p<sub>3</sub>, the valve is working within the control range.

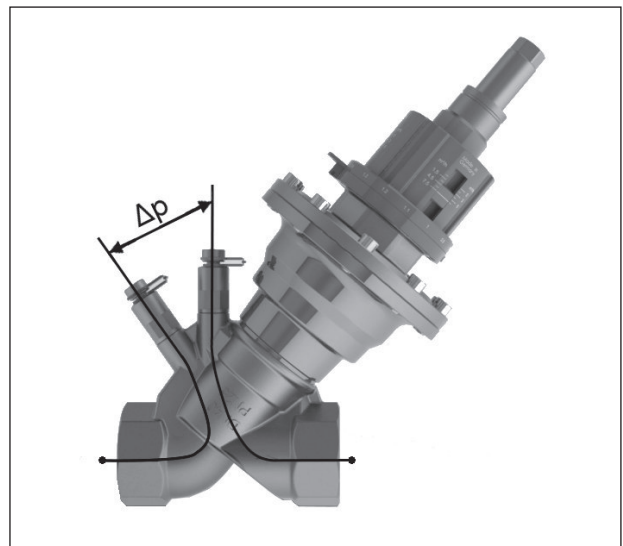

Differential pressure

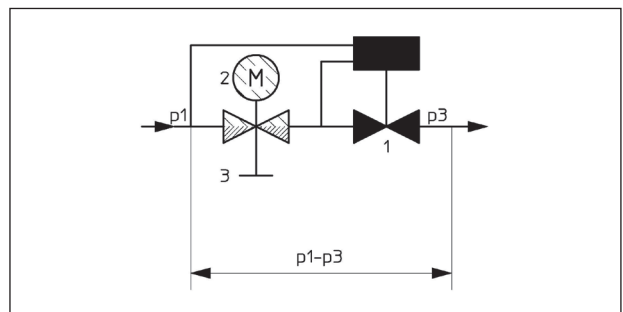

With a measuring system connected (e.g. “OV-DMC 3”), the differential pressure (p<sub>1</sub>-p<sub>3</sub>) is measured across the valve.

Subject to technical modifications without notice.

Product range 3  
ti 238-EN/10/MW  
Edition 2018