

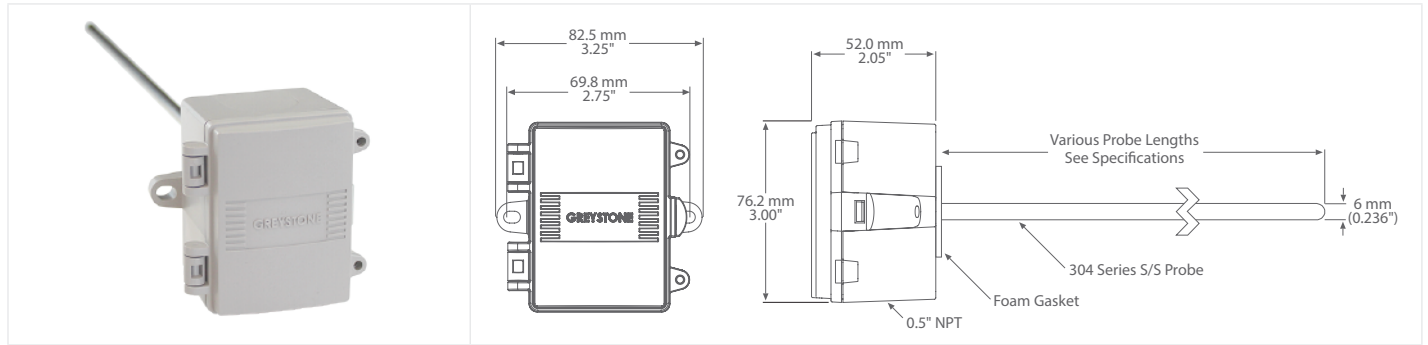

HIGH ACCURACY ALL PURPOSE DUCT TEMPERATURE SENSOR



HATSAP SERIES

PRODUCT DESCRIPTION

The high accuracy all purpose single point temperature sensor utilizes a precision sensor encapsulated in a 6 mm (0.236") OD, 304 series stainless steel probe and is available in various lengths (see ordering chart). All probes provide excellent heat transfer, fast response and resistance to moisture penetration.

TYPICAL INSTALLATION

For complete installation and wiring details, please refer to the product installation instructions.

In duct applications the probes are installed in the side of the duct to monitor a single point temperature within the duct. Select a probe length that allows the probe to span the duct width. Install the probe in a straight section of duct at a suitable distance downstream from any heating, cooling, or humidification devices.

For immersion applications ensure the probe is installed in the appropriate length thermowell for the pipe size. Thermal conductive compound should be added inside the thermowell to provide optimum thermal transfer.

For immersion applications, a T2 Series thermowell is required. When using a T1 series thermowell an adapter will be required.

SPECIFICATIONS

| | |
|---|--|
| SENSOR TYPE | Various Thermistor or RTD |
| SENSOR ACCURACY (ACCURACIES LISTED ARE APPLICABLE TO SENSING ELEMENT ONLY) | RTD Class A: $\pm 0.15^{\circ}\text{C}$ ($\pm 0.27^{\circ}\text{F}$) @ 0°C (32°F) RTD 1/3 DIN: $\pm 0.1^{\circ}\text{C}$ ($\pm 0.18^{\circ}\text{F}$) @ 0°C (32°F) RTD 1/10 DIN: $\pm 0.03^{\circ}\text{C}$ ($\pm 0.054^{\circ}\text{F}$) @ 0°C (32°F) NTC Thermistor Type 39: $\pm 0.05^{\circ}\text{C}$ ($\pm 0.09^{\circ}\text{F}$), 0 to 70°C (32 to 158°F) NTC Thermistor Type 55: $\pm 0.03^{\circ}\text{C}$ ($\pm 0.054^{\circ}\text{F}$), 0 to 70°C (32 to 158°F) NTC Thermistor Type 40/46: $\pm 0.1^{\circ}\text{C}$ ($\pm 0.18^{\circ}\text{F}$), 0 to 70°C (32 to 158°F) |
| PROBE SENSING RANGE | RTD: -20 to 100°C (-4 to 212°F) Thermistors: -40 to 100°C (-40 to 212°F) |
| AMBIENT OPERATING RANGE | -40 to 50°C (-40 to 122°F), 5 to 95 %RH non-condensing |
| WIRE MATERIAL | RTD: FT-4, 22 AWG, 3 Wire Thermistor: PVC insulated, parallel bonded, 22 AWG, 2 Wire |
| PROBE MATERIAL | 304 series stainless steel |
| PROBE DIAMETER | 6 mm (0.236") |
| STANDARD LENGTHS | 50, 100, 150, 200, 300, and 450 mm (2", 4", 6", 8", 12", and 18") |
| ENCLOSURE | ABS, UL94-V0, IP65 (NEMA 4X) C: includes terminal block E: same as C, with thread adapter (1/2" NPT to M16), and cable gland fitting |
| TERMINATION | A: pigtail, 2 or 3 wire C & E: terminal block, 2 or 3 wire |
| COUNTRY OF ORIGIN | Canada |

NOTE: The sensor accuracies listed in the specifications section apply to the sensing element only prior to product assembly and may not be reflected in the complete assembly.

Due to the measurement uncertainty, it is possible, that the true resistance value of the single delivered sensor at 0°C can be out of the defined tolerance class. Profiling each assembly to take into consideration lead wire and the attachment method should be completed.

MOUNTING STYLES

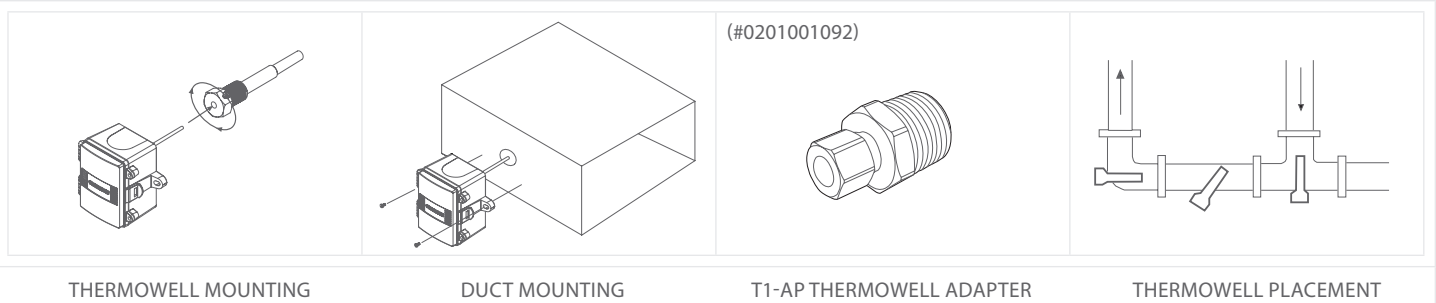



ACCESSORIES - INCLUDED WITH E ENCLOSURE OPTION

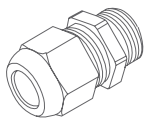

CABLE GLAND FITTING

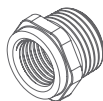

THREAD ADAPTER 1/2" NPT TO M16

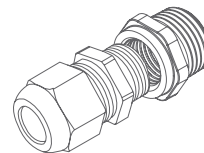

ORDERING

| PRODUCT | HATSAP | High Accuracy All Purpose Duct/Immersion Temperature Sensor |
|--------------|-------------|--|
| ENCLOSURE | A | ABS, with hinged and gasketed cover |
| | C | Same as A, with terminal block |
| | E | Same as C, with thread adapter and cable gland fitting |
| SENSOR | 18 | 1000 Ω Platinum, 3 wire, IEC 751, 385 Alpha, thin film, Class A |
| | 48 | 1000 Ω Platinum, 3 wire, IEC 751, 385 Alpha, thin film, 1/3 DIN |
| | 22 | 1000 Ω Platinum, 3 wire, IEC 751, 385 Alpha, thin film, 1/10 DIN |
| | 39 | 10,000 Ω Type 2, NTC Thermistor, ±0.05°C |
| | 55 | 10,000 Ω Type 2, NTC Thermistor, ±0.03°C |
| | 40 | 10,000 Ω Type 3, NTC Thermistor, ±0.1°C |
| PROBE LENGTH | 46 | 20,000 Ω NTC Thermistor, ±0.1°C |
| | A | 50mm (2") |
| | B | 100mm (4") |
| | C | 150mm (6") |
| | D | 200mm (8") |
| | E | 300mm (12") |
| F | 450mm (18") | |

PART NUMBER

| HATSAP |
|--------|
| |
| |
| |
| |
| |
| |
| |

NOTE: Greystone Energy Systems, Inc. reserves the right to make design modifications without prior notice.



Greystone Energy Systems, Inc.
150 English Drive, Moncton,
New Brunswick, Canada E1E 4G7

Ph: +1 (506) 853-3057 Fax: +1 (506) 853-6014
North America: 1-800-561-5611
E-mail: mail@greystoneenergy.com