

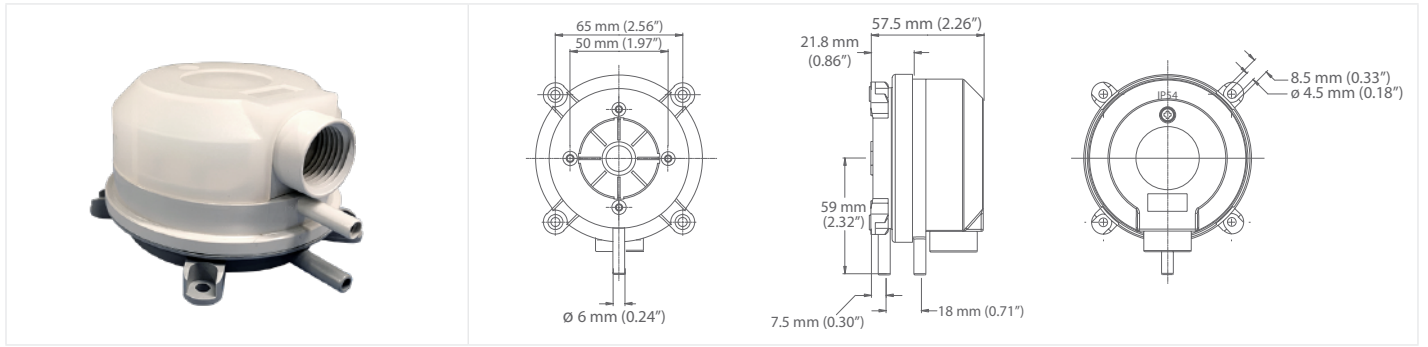

## DIFFERENTIAL PRESSURE SWITCH - MULTI-PACK



### GFS SERIES

### PRODUCT DESCRIPTION

The differential pressure switch housing unit contains a diaphragm, a snap-acting SPDT switch, and a range adjustment knob with increments. The sample connections located on the side accept 6.35mm (0.25") OD tubing. There are 2 pressure ranges available. The enclosure cover guards against accidental contact with the live switch terminal screws and the setpoint adjustment knob with indication.

45 piece multi-pack.

### ALARM OR CONTROL

To prove excessive airflow or pressure

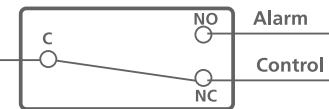

To prove insufficient airflow or pressure

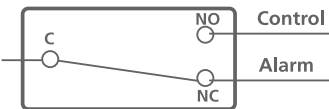

### SPECIFICATIONS

ADJUSTMENT RANGE	See product ordering information
ADJUSTMENT KNOB MARKINGS	Scaled in Pascal and "WC
SWITCH TOLERANCE	±15%
SWITCH REPEATABILITY	<b>80:</b> +/-5%, min +/- 5 Pa <b>83:</b> +/-2.5%, min +/- 5 Pa
MAXIMUM OPERATING PRESSURE	1.45 PSI (10 kPa) for all pressure ranges
MEDIUM	Air, non-combustible, and non-aggressive gases
TEMPERATURE RANGE	<b>Medium and ambient temperature:</b> -20 to 60°C (-4 to 140°F) <b>Storage Temperature:</b> -40 to 85°C (-40 to 185°F)
DIAPHRAGM MATERIAL	Silicone, tempered at 200°C, free of gas emissions
PRESSURE CONNECTIONS	2 plastic pipe connection pieces (P1 and P2), external diameter 6.0mm P1 for connection to higher pressure P2 for connection to lower pressure
ELECTRICAL RATING	Max. 1.0A (0.4A) / 250 Vac, 50/60 Hz Max. 0.1A / 24 Vdc
ELECTRICAL CONNECTIONS	AMP flat plug 6.3mm x 0.8mm Push-on screw terminals Cable conduit with cable relief
MECHANICAL WORKING LIFE	Over 10 million switching operations
HOUSING MATERIALS	Switch body made of PA 6.6, cover made of PC
PROTECTION CATEGORY	IP54 with cover (NEMA 13)
WEIGHT	With cover 160g
APPROVALS	CE
AVAILABLE ACCESSORIES	<b>DDP-Installkit-MP:</b> 45 piece multi-pack of duct install kits, each including 2 meters of PVC hose and 2 ABS tubes

### ORDERING

PRODUCT RANGE	<b>GFS-</b>	Adjustable Differential Pressure Switch with Setpoint Indication
	<b>80</b>	20 to 300 Pa (0.08" to 1.20" WC), Switch differential 10 Pa (0.04" WC)
	<b>83</b>	50 to 500 Pa (0.2" to 2.00" WC), Switch differential 20 Pa (0.08" WC)
ADDITIONAL DESCRIPTION	<b>C-NPMPN</b>	CE only, 1/2" NPT, Multi-pack - 45PCS per carton, no duct install kit, non-branded

NOTE: Greystone Energy Systems, Inc. reserves the right to make design modifications without prior notice.

### PART NUMBER

<b>GFS-</b>